

# A Review Paper on Garbage Level Monitoring System for Smart Cities

Neha Ganvir<sup>#1</sup>, Sujay Deshpande<sup>#2</sup>, D.M.Yadav <sup>#3</sup>

Department of E&TC, KJCOER&M, S.P.Pune University<sup>#1</sup>

Department of E&TC, APCOE&R, S.P.Pune University<sup>#2</sup>

Principal, S. N. D. College of Engineering & Research Center, Yeola<sup>#3</sup>

ganvirneha@gmail.com<sup>1</sup>

soojeydeshpande@gmail.com<sup>2</sup>

dineshyadav800@gmail.com<sup>3</sup>

## Article Info

Page Number: 13210-13219

Publication Issue:

Vol. 71 No. 4 (2022)

**Abstract:** As the population is increasing day by day, the environment should be clean and hygienic. In many of the cities the overflowing garbage bins are creating an unhygienic environment. This further leads to arise of different types of diseases. To cope up with the situation, Shree Narendra Modi, PM of India has presented a unique example of a way to achieve cleanliness by launching a campaign popularly known as SWACCHHA BHARAT ABHIYAN (CleanIndia Mission) in which every individual irrespective posts and authority, has to maintain clean surrounding. In this contemporary busy world, it is almost impossible to maintain the clean and hygienic environment. To overcome these situations, we need to implement a smart garbage level monitoring system, which will alert the municipal corporation or higher authorities about the current level of garbage in different zones of cities. As level reaches its threshold level the alert is send to corporation. As the notification is received by the municipal corporation, the rag picking truck will reach to that dustbin and will empty the bin. Hence the bins are emptied before the garbage starts overflowing.

**Keywords:** ultrasonic sensor, wi-fi module, IoT.

## Article History

Article Received: 25 October 2022

Revised: 30 November 2022

Accepted: 15 December 2022

---

## Introduction

A smart city is an urban development to integrate information and communication technology (ICT) and Internet of things (IoT) technology in a secure way to manage a city's requirements. Information and communication technology (ICT) helps to enhance quality, performance and interactivity of urban cities, to reduce costs and resource consumption and to enhance communication between people and government. It's a city with high-tech communication capabilities. It uses digital technology to improve performance and well-being, to reduce costs and resource consumption, and to engage more efficiently with its

13210

people. There are many huddles in formation of smart cities like, pollution, firefighting, housing, waste disposal, public transport, shortage of electric power, security etc. Some of them are explained below as:

**Housing:** The most important concern in all cities has been housing the sudden and large-scale inflation of migrants from rural areas to urban areas especially the metropolitans and state capitals. Due to lack of housing, in each city almost fifty percent population lives in slums. Slums are illegally created colonies of housing on open spaces in the cities. The structures are temporary they are very crowded and rows of such houses are separated by narrow lanes through which household drainage can flow. These colonies do not have any civic amenities like drinking water, sewage, electricity etc. Ideally, slums should be cleared and housing apartment buildings should be constructed by the government to accommodate all the slum dwellers.

**Pollution:** Pollution is the introduction of contaminants into the natural environment that cause adverse change and damage to the society. Pollution can take the form of chemical substances or energy, like noise, heat or light. Pollutants, the components of pollution, can be either foreign substances/energies or naturally occurring contaminants. Pollution is often classified as point source or non-point source pollution. There are many types of pollution like air pollution, water pollution, etc.

**Waste Disposal:** Another big problem that has come up due to the large increase in population has been the enormous amount of solid waste generated. In a city like Bengaluru the solid waste generated is estimated to be around 5000 tons per day. The collection, transportation and disposal of this huge quantity of solid waste is becoming serious problems for the municipality. Finding dumping grounds for this waste has become very difficult. Dumping this sort of waste has created serious problems of pollution, ill-health and stink to inhabitants nearby. Much research needs to be done on the disposal of various types of solid waste without causing any harm to the environment. To overcome these problems a smart city initiative “Swachh Bharat Abhiyan” has been launched by our Prime Minister Mr. Narendra Modi exhorted people to fulfil Mahatma Gandhi's vision of Clean India, which covers 4,041 cities and towns, to clean the streets, roads and infrastructure of the country. The main motto of the mission is to cover all the rural and urban areas of the country, with proliferation of Internet of Things (IoT) [1]. It's India's largest cleanliness drive with 3 million government employees, especially school and college students from all parts of India, participating in the campaign ever. Our domain knowledge covers garbage level monitoring system for smart cities. Garbage level monitoring system for smart cities is a very innovative system which will help to keep the cities clean and healthy. It monitors the garbage bins and informs about the garbage level in the bins via mobile app to the respective authority concerned. Ultrasonic sensors are placed at the top of the bins to detect the garbage level and compare it with depth of garbage bins. Smart garbage collection system for cities assures the cleaning of bins as soon as the garbage level reaches to its maximum level. If the dustbin is not cleaned in specified time, then the notification alert is sent to the higher authority who can take immediate required action against the concerned official. The main aim of this project is cleanliness of the areas where trash bins are located and the management that it

contains with it. Essentially this project is about collecting the most amounts of garbage in the least amount of time to reduce cost and emissions. Thus, there will be saving in fossil fuel due to optimized route for collecting garbage and thus reducing transportation cost.

## 1. Background

Solid waste management (SWM) is a major concern for many urban local bodies (ULBs) in India, where urbanization, industrialization and economic growth have resulted in drastic increased municipal solid waste (MSW) generation per person [5]. As pressure has mounted for more eco-friendly waste management, the industry has increasingly become involved in environmental policy. Generally solid waste is defined from the household refusal. The non-hazardous solid wastes are from industries, institutions such as hospitals, markets and streets. All these types of solid waste are a problem to environment. In developing countries, waste management is becoming a social issue due to unmonitored act. A significant amount of solid waste generated in country are not collected and managed properly leading to pollution. Wastes are either burned openly on the streets or end up with empty land, rivers and thereby creating a serious health issue to public and society. India faces major environmental challenges associated with these waste generation and inadequate waste collection, transport, treatment and disposal. Current systems in India cannot cope up with the amount of waste generated by an increasing urban population, and its impacts on the environment and public health. Population growth and particularly the development of megacities is making SWM in India a major concern. The status of SWM in India is poor because the best and most appropriate methods from waste collection to disposal are not being carried out. There is a lack of training in SWM and the availability of qualified waste management professionals is less. The current situation in India relies on inadequate waste infrastructure, the informal sector and waste dumping management. There are major concerns associated with public participation in waste management and there is generally a lack of responsibility towards waste management in the community. There is an immediate need to cultivate community awareness and change the attitude of people towards waste, as it is fundamental in developing proper and sustainable waste management system. Sustainable and economically viable waste management must ensure maximum valuable resource extraction from waste, combined with safe disposal of residual through the development of engineered landfill and waste-to-energy advanced facilities. India faces challenges related to waste policy, waste technology and the availability of appropriately trained people and employees in the waste management sector. Until these fundamental requirements are fulfilled, India will continue to suffer poor waste management and the associated impacts on the environment and public health. In the year 2012, first time in history of India it was seen that there were many public protests about improper solid waste management all over the country. A fight and demand for the right to clean environment and environmental justice led the citizens to large scale demonstrations, including an indefinite hunger strike and blocking roads leading to local waste handling amenities. Improper waste management has also led to Dengue Fever outbreak and threatens other diseases.

A strong and independent authority is required to regulate waste management if SWM has to improve in India. Without clear regulation and enforcement, improvements will not take

place. Strong waste regulations and enforcements can drive innovation. The waste management sector needs to include attractive and profitable businesses with clear performance requirements imposed by the ULB (Urban Local Bodies), with financial penalties applied when waste management services are not working effectively.

## **2. Relevance**

Improper disposing of waste has large environmental impacts and can cause serious problems to society. In the London much of the waste is buried in landfill sites like holes in the ground, sometimes old quarries, sometimes specially dug. Some waste will eventually rot, but not all, and in the process, it may smell or generate methane gas, which is explosive and dangerous contributing to the greenhouse effect. Leach ate produced as waste decomposes cause pollution. Badly- managed landfills may attract vermin and cause litter. Incinerating waste also causes problems, because plastic tends to produce toxic substances in air, such as dioxins, when they are burnt. Gases from incineration may cause air pollution and contribute to acid rain, while the ash from incinerators contains heavy metals and other toxin elements. Because of these issues there are active campaigns against waste incineration all around.

Waste management measures make an efficient contribution in cost-effective reduction of greenhouse gases. The necessary steps for restructuring a “climate-friendly waste management sector” is known, and reliable recycling and waste treatment techniques are available. A phase-out of the landfill of untreated waste, accompanied by an increase in recycling rates and energy-efficient treatment of residual waste, immediately results in successes in greenhouse gas reduction. In 1990, the German municipal waste management sector burdened the climate with nearly 38 million tonnes of climate-damaging gases. However today, it relieves the climate actively of 18 million tonnes per year. The resultant savings of 56 million tonnes of CO<sub>2</sub> equivalents achieved by the sector compared to 1990 correspond to about one- quarter of the total reduction in greenhouse gas emissions achieved in Germany up to 2006. Methane emissions from landfills, formed by anaerobic breakdown of organic matter, are the main contributor to the sector’s greenhouse gases. Germany reports in the National Inventory Report, about its greenhouse gas emissions to the United Nations Climate Secretariat, credits the German waste management sector with an emission reduction of about 28 million tonnes of carbon dioxide equivalents (for the period 1990 to 2008), thanks to the reduction of waste volumes sent to landfill and use of the landfill gas methane to produce energy. Further contributions to greenhouse gas reduction will result from waste streams shifting from landfill towards increased recycling and energy recovery from residual waste.

## **3. Project Undertaken**

Internet of Things (IoT) is nothing but the applications performing with the help of internet. It is an advanced domain of technology in which all your data is stored on the cloud server with real time access to data as well as its data mining. While the data is stored on the cloud server and people having the internet access, will provide a great access to people on the same application from anywhere in and around the globe. Such advancement also requires sensors

and routers for gathering and sending data over the internet. Such domains can be used in all sorts of Pervasive Computing, and Business Intelligence applications. This proposed system introduces the use of IoT on one such area, i.e. Garbage Level Management in smart ways using IoT and see how this can also play a major role of developing a city into a smart city. In this project we are going to monitor the garbage level. The level of the garbage in the dustbin is calculated by using an ultrasonic sensor, and the same will be displayed on LCD screen. As the bin overflows the notification will be send to Municipal Corporation and the status of the same will be stored on thingspeak web server.

## I. Related Work

In literature various methods are used to analyse the level of garbage in public bins. In past some research had been already done on waste management system using Arduino, GSM, IR sensors and using RFID tag also.

Bharadwaj B, M Kumudha, Gowri Chandra N, Chaithra G proposed “Automation of smart waste management using IOT to support “Swachh Bharat Abhiyan” [1]. In this paper as shown in table 2.1 they proposed the effective dry and wet dirt collection using Embedded System. The main work of the application is collection of dry and wet waste separately which is placed in a conveyor belt on which the dry waste collected bins are placed left side and wet waste collected bins on right side. The system will get the input from the dust collecting person through switches and sends signal to the Microcontroller unit using RF technology and that makes the H-bridge to rotate conveyor belt. When the belt starts rotating clockwise the dust bin’s lid is automatically closed, simultaneously the waste is dumped into the underground garbage container placed at the ground floor. Here IoT module is used to control and monitor the waste and the information will be sent to the municipal organization and the common man. The mobile app shows the collection of waste and the date and arrival time of the vehicle.

Dr.N. Sathish Kumar, B. Vijayalakshmi, R. Jennifer Prarthana, A. Shankar proposed “IOT Based Smart Garbage alert system using Arduino UNO” [3]. This paper proposes a smart alert system for garbage clearance by giving an alert signal to the municipal web server for instant cleaning of dustbin with proper verification based on level of garbage filling as shown in table 2.1. This process is aided by the ultrasonic sensor which is interfaced with Arduino UNO to check the level of garbage filled in the dustbin and sends the alert to the municipal web server once if garbage is filled. After cleaning the dustbin, the driver confirms the task of emptying the garbage with the aid of RFID Tag.

Trushali S. Vasagade, Shabanam S. Tamboli, Archana D. Shinde invented “Dynamic Solid Waste Collection and Management System Based on Sensors, Elevator and GSM” [2]. In this system they proposed a smart solid waste management system which is designed to check the status and give alert of dustbin fullness. This paper is focused on monitoring the dustbin status and giving its alerts to City Corporation as well as focuses on these on-field issues like improper use of dustbin which makes the surrounding area dirty and unhygienic. As shown in table 2.1 the objective of giving alert to the Corporation gets achieved by the GSM system. IR

sensor is used to sense the fullness of dustbin and garbage outside the bin. The IR sensor which is placed to play role of sensing garbage outside the dustbin will enable the mechanical assembly so as to clean that garbage and put it back into the dustbin properly.

Radek Fujdiak, Pavel Masek, Petr Mlynek, Jiri Misurec, Ekaterina Olshannikova invented "Using Genetic Algorithm for Advanced Municipal Waste Collection in Smart City" [4]. As shown in table 2.1 this paper uses their own genetic algorithm implementation to optimize the logistic procedure of waste collection. The presented solution provides calculation of more efficient garbage-truck routes. As an output, they provide a set of simulations focused on mentioned area. All their algorithms are implemented within the integrated simulation framework which is developed as an open source solution with respect to future modifications.

## **II. About Proposed System And Flow Of System**

### **1. Proposed Methodology**

In the traditional approach whenever a garbage overload is found manually a truck comes to clear the over dumped wastage. But it is not occasionally monitored. It is very important to periodically monitor the trucks and record the information that has relevance to the collecting time and area from a central location to ensure that the job is done right. This proposed system is designed in such a way that it avoids the overflow of the dustbin by sending alerts to the municipal corporation with help of a microcontroller linked with a thingspeak channel using IoT.

It consists of the PIC18F877A microcontroller, Ultrasonic module HC - SR04, 16\*2 LCD display, Wi-Fi module ESP8266 where PIC16F877A is a master controller and all rest parts are interfaced with it. Ultrasonic ranging module HC-SR04 offers a 2-450cm non-contact measurement function, the ranging accuracy is up to 2mm. Here electrical energy is transformed into sound to send the pulse. The sound that is received back is converted into electricity. Thus, the time lag between the sent and received sound signal is used to estimate the distance to the object. The level of the garbage in the dustbin is calculated by using an ultrasonic sensor. Microcontroller PIC18F877A is used to read the data from the ultrasonic sensor. It is programmed to send an alert to the concerned department to collect the garbage, when the garbage reaches its threshold height of the dustbin. If the bins will not get cleaned in specific time the garbage will starts overflowing and buzzer will ring The garbage levels are sent to the Thing speak cloud. The data will be stored and will be displayed in graphs on thingspeak. An android application is used to view the alerts and status at the server end.

### **2. Flow of the system**

#### **a. Flowchart 1:**

Figure 1(a) shows the step by step procedure of garbage level monitoring system as follows.  
Step1: Initialize the LCD display.

Step2: To start the ultrasonic sensor microcontroller will send the trigger pulses to it. Step3:

measure the level of garbage inside the bins.

Step4: The current status of garbage level will be checked by the microcontroller, is bin 75% filled or not?

Step5: If yes then microcontroller will send the notification to concerned department, and if bin is not filled up to 75% then system repeats the step no 4.

Step6: After receiving the notification by department, it will send the garbage picking truck to collect the garbage from the bin, and empty it.

Step7: If truck will arrive then the bin will be get emptied by them. Step8: If truck will not arrive then check the conditions of B.

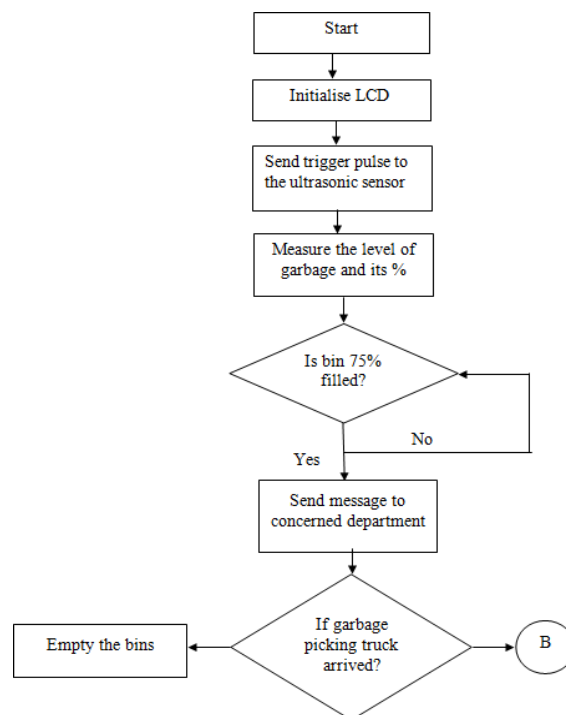
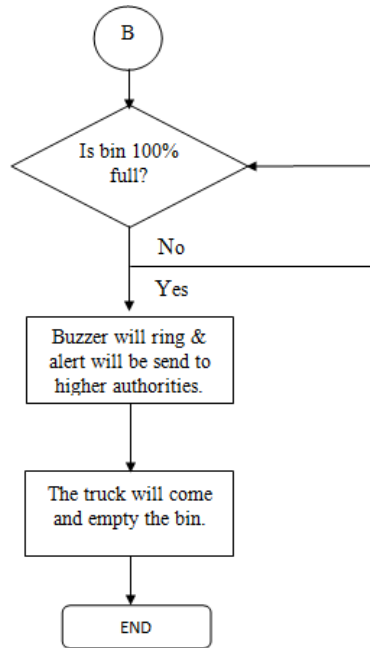

**Fig.1 Flow chart 1**

Now the garbage level is reaches to its 75% but still if the truck had not arrived then the further conditions is shown in figure 2. Now as the bin is continuously getting filled it may get overflowed after some time.

1. If bin is filled 100% then buzzer will ring and alert will be send to the higher authorities, and if not, then the level will be continuously checked.

2. After receiving the message by higher authorities, they will send the garbage picking truck and bins will get emptied by them



**Fig.2 Flow Chart 2**

### III. Design And Architecture Of System

#### 1. Block Diagram and block diagram description

In this project we have to send the notification alert to the municipal corporation as the garbage level reaches its threshold level. Figure 3 show the block diagram of the garbage level monitoring system for smart cities and garbage level is displayed on the screen.

As in fig 2, block diagram contains two ultrasonic sensors one for wet bin and another one for dry bin i.e. HC-SR04, PIC16F877A microcontroller, 230 V power supply, buzzer, ESP8266 Wi-Fi module and 16\*2 LCD display.

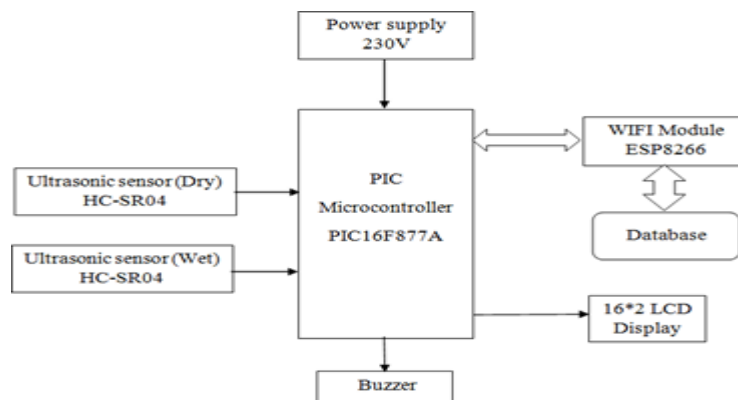

**Fig.3 System Block Diagram**



### **Block description in detail**

- 1. Ultrasonic sensor:** In this project we used ultrasonic ranging module HC-SR04 offers a 2-450cm non-contact measurement function, the ranging accuracy is up to 2mm. It has 5V (DC) working voltage, with static current less than 2mA.
- 2. Wi-Fi Module:** In this project we are going to use a ESP8266 Wi-Fi module which establishes wireless connectivity between microcontroller and web server.
- 3. Buzzer:** As the garbage level of the bin reaches to its maximum height that is 100%, then the buzzer will ring and alert will be send to the higher authorities.
- 4. Microcontroller:** Here we used PIC16F877A microcontroller, which operates with a 12 MHz crystal. It is a master controller whereas rest all parts are interfaced with it.
- 5. LCD Display:** The LCD module (16\*2) is used to display the status (garbage level) of the bins.
- 6. Power Supply:** Power supply is of 230 V, which is given to transformer which step down the voltage to 9V. Then this step-down AC is converted to DC. By using regulator this DC is regulated to 9V to operate whole circuit.

### **Selection of Components Microcontroller:**

As this project is to be implemented in many areas of the city. So, we need low power and low cost microcontroller, that's why we selected the PIC16F877A microcontroller. It has following specifications: It has a low power consumption. High speed flash technology. It has a low power consumption. 10 bits analog to digital converter with 8 channels. Operated at wide voltage range 2.0V to 5.5V. It has special feature of power saving sleep mode.

### **Ultrasonic Sensor:**

The level of the garbage in the bins is to be measured therefore we need ultrasonic sensor for the same. We selected the HC SR04 because of its following specifications. It has 2cm-450cm measuring range with precision accuracy of 2mm. Its operating voltage range is 5V Dc with static current less than 2mA. Sensing angle less than 15 degrees.

### **ESP 8266:**

The network is required to upload the garbage level on the thingspeak webserver. Wi-Fi module ESP8266 establishes the wireless connectivity between microcontroller and web server. It is a low cost Wi-Fi module suitable for adding Wi-Fi functionality to an existing microcontroller project via a UART serial connection. The ESP8266 requires 3.3V for its operation.

### **Conclusion & Future Scope**

The implementation of smart garbage collection system for smart cities, assures the cleaning of dustbins. Up till now we have simulated our expected circuit diagram and we have getting

the expected result. The channel id is created on thingspeak channel which is used to store the data and it gives the graphical representation of status of garbage level inside the bins.

### **Future Scope**

We should implement this system in several areas of the cities, some area may not have a continuous power supply for this system to be worked efficiently. This issue can be solved by using solar panels in future. Solar panels can be used with the solar batteries which do not require a continuous power supply. Secondly, we can add the suction pipes with compressors at the bottom of the bins, which will directly suck the wet garbage from the bin and will dump it in dump yard.

### **References**

- [1] Bharadwaj B, M Kumudha, Gowri Chandra N, Chaithra G, “Automation of smart waste management of smart waste management using IoT to support Swachh Bharat Abhiyan”, Computing and Communications Technologies (ICCCT), 2017 2nd International Conference on Feb. 2017
- [2] Trushali S. Vasagade, Shabanam S. Tamboli, Archana D. Shinde, “Dynamic Solid Waste Collection and Management System Based On Sensors, Elevator and GSM” Inventive Communication and Computational Technologies (ICICCT), 2017 International Conference, March 2017
- [3] Dr.N.Sathish Kumar, B.Vuayalakshmi, R. Jenifer Prarthana, A .Shankar, “IOT Based Smart Garbage alert system using Arduino UNO”, Region 10 Conference (TENCON), 2016 IEEE
- [4] Radek Fujdiak, Pavel Masek, Petr Mlynek, Jiri Misurec, “Using Genetic Algorithm for Advanced Municipal Waste Collection in Smart City”, Communication Systems, Networks and Digital Signal Processing (CSNDSP), 10th International Symposium on July 2016